

# WORLD MARKET®

## Assembly Instructions

SORANO ROPE MODULAR OTTOMAN

SKU - 619230

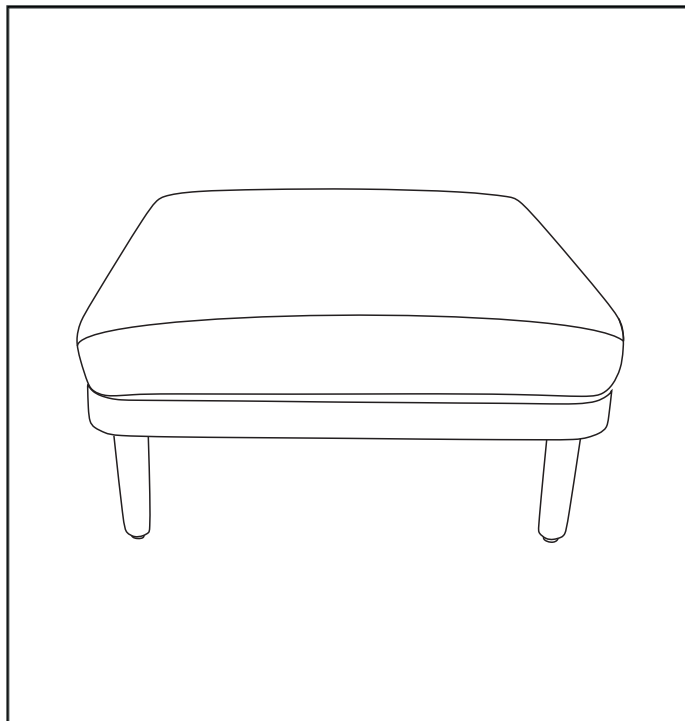

THANK YOU FOR YOUR PURCHASE. IF YOU HAVE ANY QUESTIONS  
PERTAINING TO THE ASSEMBLY OF THIS FURNITURE PIECE, PLEASE CONTACT  
THE NEAREST WORLD MARKET STORE.  
IF YOU ARE NOT NEAR A STORE, PLEASE CALL OUR CUSTOMER SERVICE CALL  
CENTER TOLL FREE AT 877- 967-5362 FOR ASSISTANCE.

All products sold at World Market are not for commercial use  
and are intended for residential use only.

# Component List

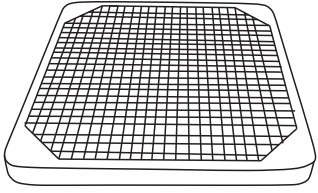
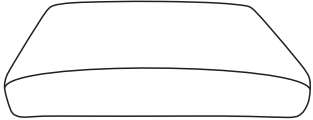
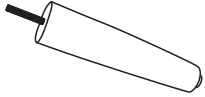
LABEL		DESCRIPTION	QTY
<b>A</b>		Seat Frame	1
<b>B</b>		Seat Cushion	1
<b>C</b>		Leg	4

# Assembly Preparation

## Before Beginning:

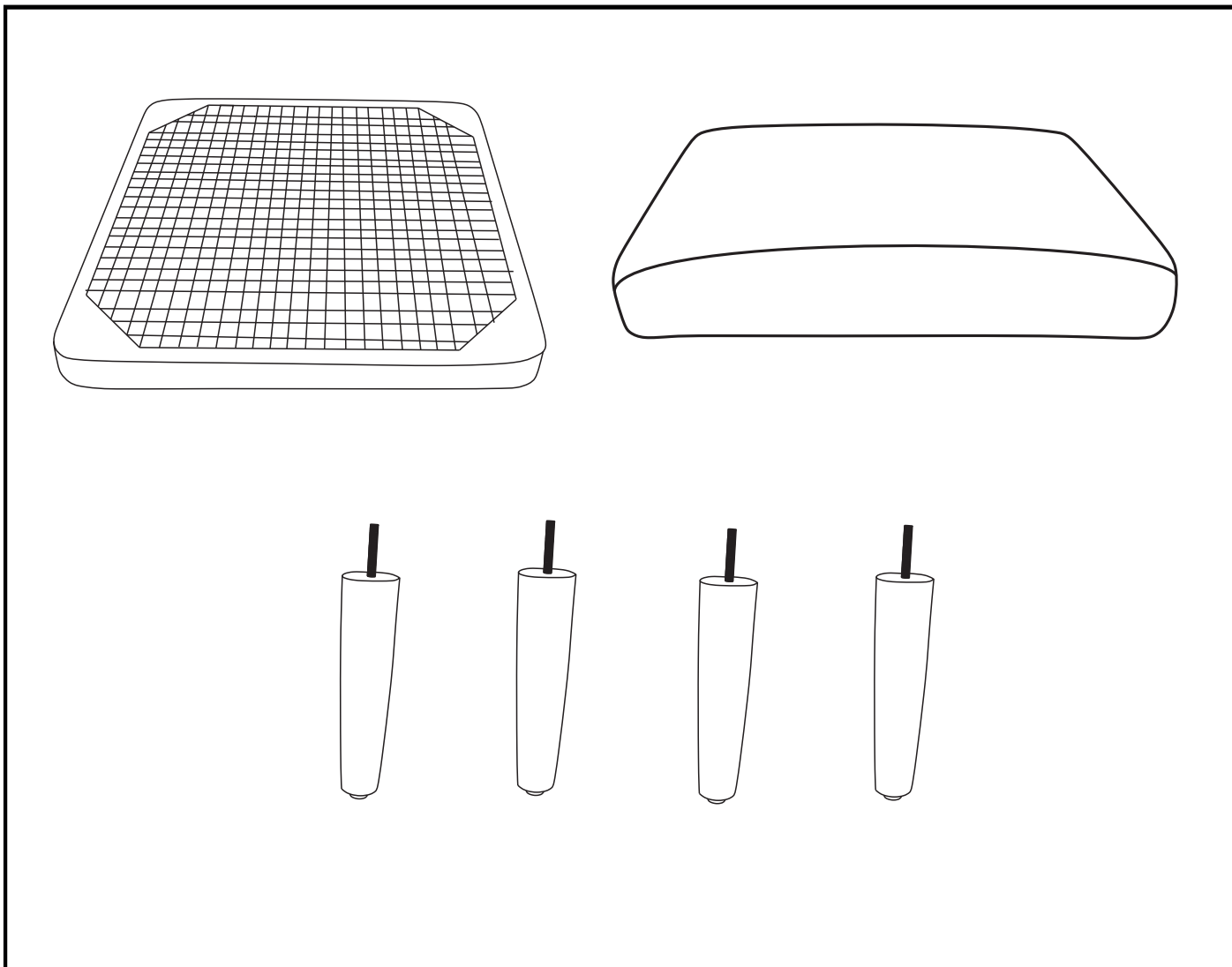

- Unpack all hardware bags and components to ensure you have all parts



- Read instructions, cover to cover



- Have 2 adults on hand for assembly



- Do not assemble on flooring or carpet



- Assemble on a clean non-marring surface (packing foam)



- Save all packaging until finished



- In case of missing parts, please contact your nearest World Market store or call our customer service call center at call 1-877-967-5362.

# Assembly steps for the legs

## Step 1

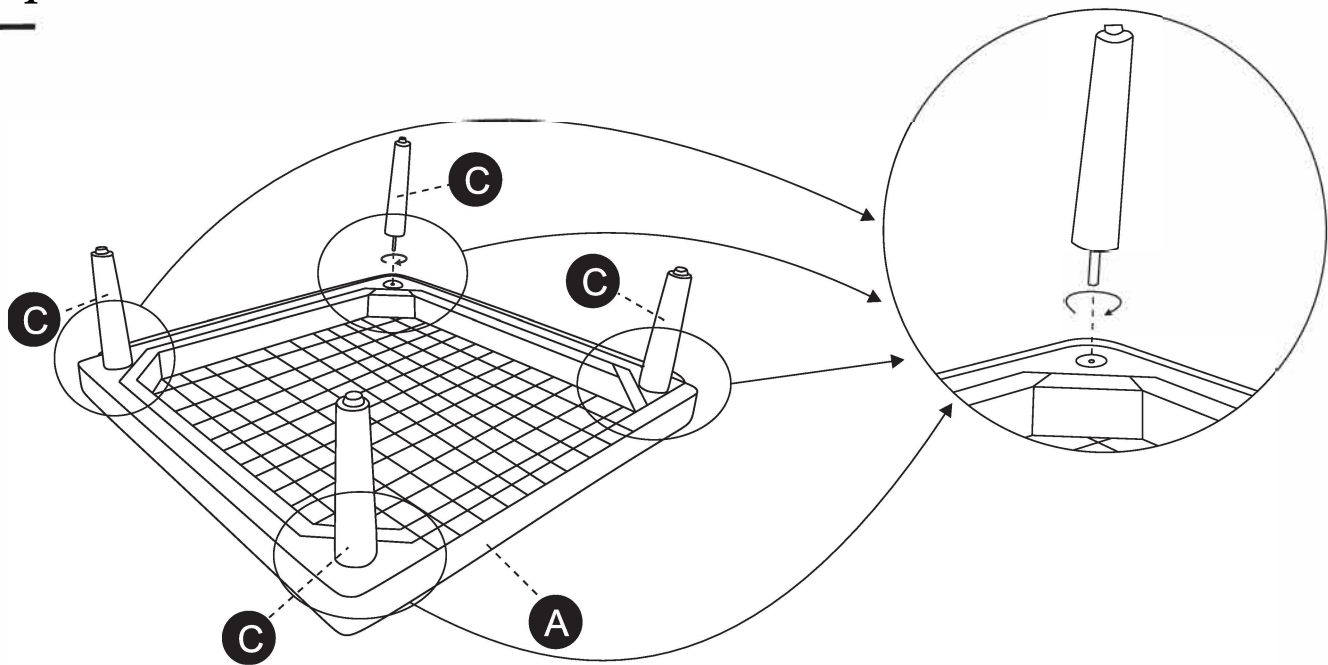

Turn Seat Frame (A) upside down on a clean, non-marring surface. Align bolts on Legs (C) with receiving holes in Seat Frame (A), as shown. Rotate Legs (C) clockwise until snug. DO NOT over tighten.

## Step 2

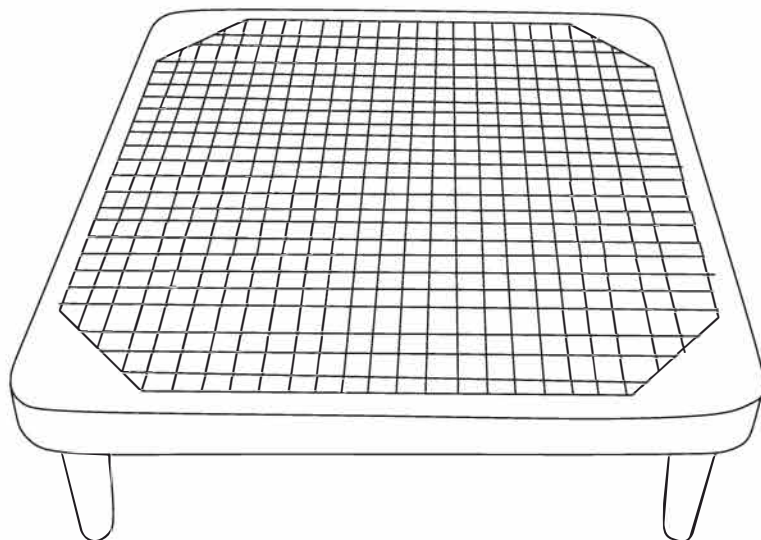

Turn Ottoman onto installed legs.

# Assembly steps for the legs

## Step 3

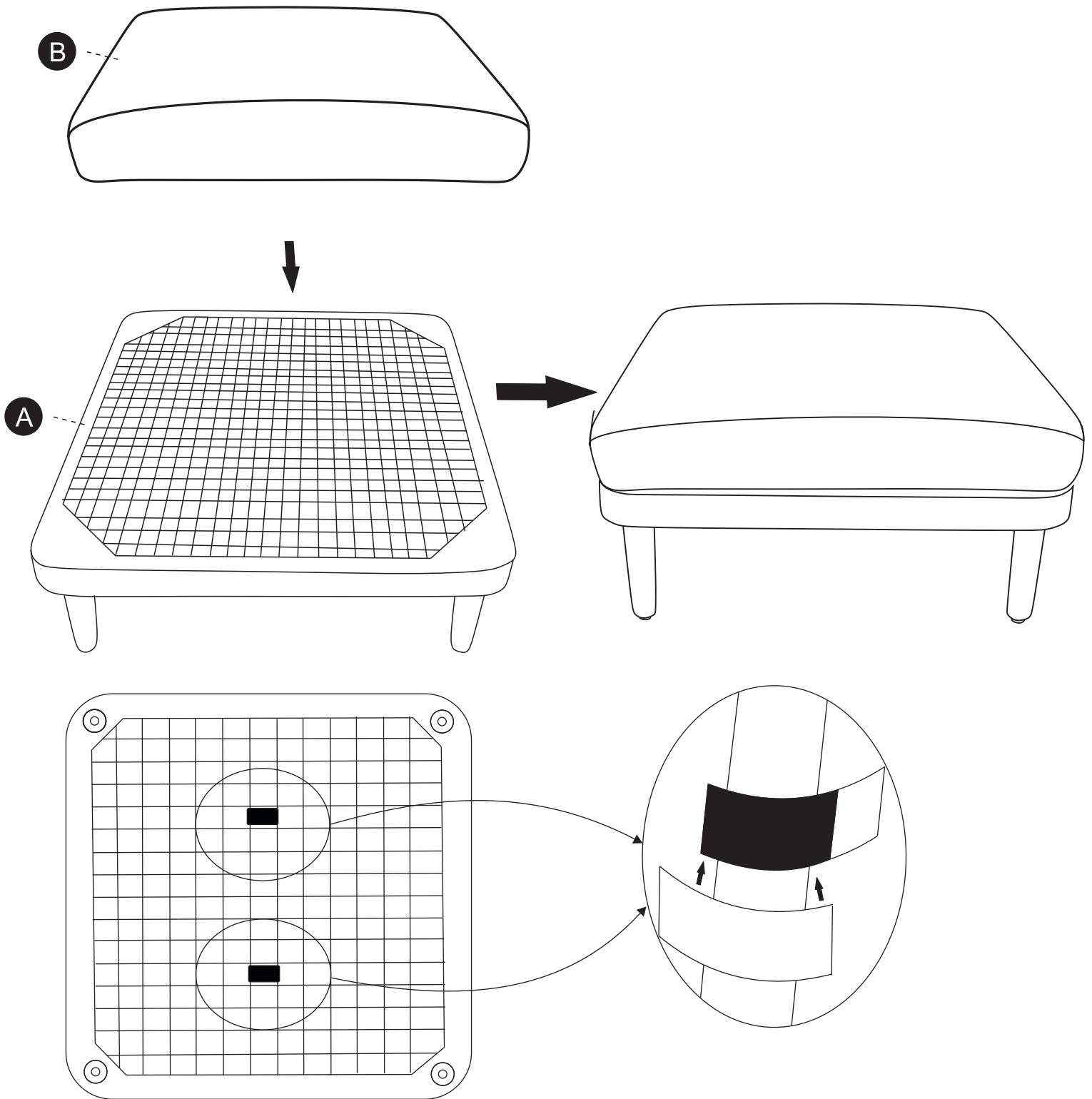







Place Seat Cushion (B) onto Seat Frame (A) as shown. Secure Seat Cushion (B) to Seat Frame (A) by wrapping Velcro strips around weaves.

Assembly is now complete and the ottoman is ready for use.

Ensure all legs are fully tightened every 3 months to ensure stability.

# Care & Maintenance

-  • Do not put hot items directly on planter surface.
-  • Do not clean planter with harsh cleansers or polish.
-  • Do not place planter near heating or cooling vents.
-  • Do not write on planter without a padded barrier to protect the surface.
-  • Store planter or use an appropriate planter cover during cold or inclement weather.
-  • All products sold at World Market are not for commercial use and are intended for residential use only.

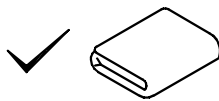
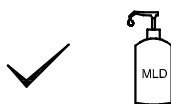
- 
-  • Dust and pick-up spills using a clean, non colored, lint-free cloth.
  -  • Stains may be removed with damp cloth.

## CAUTION:

As with any wood, the color may fade if left in direct sunlight or inclement weather. Minor cracking may occur with age. These are naturally occurring features of wood and do not affect product performance.

We recommend using our Outdoor Wood Furniture Finish sold separately to help preserve and protect the wood and finish.

## CUSHION AND SLIP COVER CARE:

For minor spots wipe with a wet cloth and use a mild detergent. Do not use bleach.

Slip covers can also be placed in a washing machine.

Remove the slip cover from the insert, do not place insert in the washing machine.

Use gentle cycle, cold water and no bleach.

Line dry, do not place in the dryer.

We use a higher density foam to ensure the cushion does not break down in the outdoor elements.

Cushion will soften over time.

Flip the cushions to maintain the quality.

For best results remove cushions during cold or inclement weather and store in a dry area.

If cushions do become wet allow to completely dry before storing to prevent mold and mildew.

# **WORLD MARKET** LIMITED ONE-YEAR WARRANTY – Outdoor Furniture

For your customer satisfaction, this product carries a **LIMITED ONE-YEAR WARRANTY** from the date of purchase. This limited warranty only applies to World Market brand furniture, and not to other furniture brands sold on World Market's website.

Where applicable, the limited warranty provides coverage for:

1. **Manufacturing, Material and Workmanship Defects:** Includes defects related to core frame/structure substrates (wood, metal and stone/tile); complete breakage of hardwood; cracking, splitting or lifting of wood veneer or laminated top surfaces caused by process failure; broken welds or improperly coated metal frame components (powder coating or painted); outdoor fabric, nautical rope and woven Textilene® defects including tears, misprints, fraying, crease marks, skip stitches or open seams; synthetic resin wicker breakage or unraveling; and other component failures that are a direct result of manufacturing or workmanship defects.
2. **Cushions:** Loss of resiliency from a material breakdown of foam or fiber filling, which should not be confused with softening or settling during normal use.
3. **Outdoor Furniture Components (Hardware & Mechanisms):** Includes defects to pre-installed components or hardware provided to the customer for assembly such as metal bases, swivel plate mechanisms; for umbrellas, canopy crank mechanism, spring loaded pole pins (for adjusting height); and other components such as bent or stripped threaded leg posts and adjustable levelers. Coverage also includes protection against rust and corrosion on hardware. For missing, damaged, corroded, or misplaced hardware components such as bolts or washers, please contact Customer Service at: 877-967-5362.

**This LIMITED ONE-YEAR WARRANTY does NOT cover:**

1. Damage due to mishandling during transportation from store or transportation without original protective packaging.
2. Abuse, negligence (product misuse), improper storage, stacking or wear and tear that may result in or from:
  - a. **Wood & Veneer:** Mishandling, prolonged exposure to moisture, peeling or discoloration caused by exposure to moisture or excessive sunlight, heat; splintered, dented or nicked panels, legs or component edges or paint/finish blemishes; or treatment with corrosive chemicals (dyes, inks, paints or harsh cleaning products). **NOTE: As with any outdoor rated wood, the color may fade if left in direct sunlight of inclement weather. Minor cracking may occur with age. These are naturally occurring features of wood and do not affect product performance.**
  - b. **Fabric (Including Sunbrella® Fabrics), Rope, Textilene®, All-Weather Wicker:** cuts, punctures, tears, burns, pet damage, or treatment with corrosive chemicals (dyes, inks, paints or harsh cleaning products), exposure to fire, high heat, water, or prolonged exposure to direct sunlight that may cause splitting, peeling, fraying or discoloration with time.
  - c. **Foam (Cushions):** Flattening, relaxing or settling/softening of foam components that comes with normal use.
  - d. **Hardware Components:** improper installation or misuse/substitution of hardware components not defined in the Assembly Instructions for the product (if applicable)
3. Damage due to prolonged environmental/inclement weather exposure such as direct sunlight, extreme heat, water or extreme humidity, strong winds, any bright light source (natural or artificial), chlorine or saltwater pools, or any environment that the product is not intended for. We HIGHLY recommend storing furniture, umbrellas and cushions with outdoor rated furniture covers and out of direct exposure during the winter or inclement weather events.
4. This warranty is applicable for outdoor furniture products purchased for residential use only.

For additional information on returns, please visit: <https://www.worldmarket.com/category/customer-service/returns.do>

**All products sold at World Market are NOT FOR COMMERCIAL USE and are intended for residential use only. Products purchased for commercial use will VOID all warranty provisions as listed above.**

Any claims under this LIMITED ONE-YEAR WARRANTY are valid and applicable only as to the original purchaser and must be accompanied by proof of purchase. Warranty claims should be submitted to a World Market store or through World Market Customer Service Call Center, Toll Free at 877-967-5362.

For valid warranty claims, World Market will repair or replace the product, or offer a full or partial credit, in the sole discretion of World Market. This LIMITED ONE-YEAR WARRANTY gives you specific legal rights and you may also have other rights which vary from state to state.

(OUTDOOR FURNITURE 1LW\_v1.3\_051122)